

REF	PART	DESCRIPTION	REF	PART	DESCRIPTION	REF	PART	DESCRIPTION
1	13-1110	Stand Upright	7		Upright Fastener 5/16-8x11/2"	16	17-1110	SR-2 Element (240V 31")
2	13-1120	Stand Upright (Crimped)	8		Screw #8 Hex Head Slotted	17	17-1156	Grill Guard
3	13-1102	Stand Base Crossbar	9	14-2555	Cross Arm Assembly	18	13-1690	High Intensity Power Cord
4	13-1100	Stand Leg (left)	10	13-1090	1/4-20 x 9/16" Male Knob		13-1080	Speed Ray 2/HT Hardware Set
4	13-1101	Stand Leg (right)	11,12	13-1095	Round Tab Washer w/ Female Knob		17-1160	Body Reflector
5		Stand Frame Bolt 3/8-16 x 3/4"	13	13-1000	End Cover/Reflector		17-1170	Lead Wire Set
6	14-2550	Set of 2" Casters (4 ea.)	14		End Cover Fastener #6 Screw		13-1460	60 Minute Timer F-60-M
	13-1140	Stand Hardware Set	15	17-1105	SR-2 Element (120V 31")		13-1600	Black Male Knob 1/4-20 x 9/16"

ASSEMBLING YOUR NEW SYSTEM

Unpack Your System: Carefully unpack your new system, making sure all parts for assembly are included. If any parts are missing, call customer service for replacement.

Assemble Stand: Install casters (6) and end caps first, then slide together legs (4) and crossbar (3). Bolt H-frame parts together with supplied 3/8" bolts (5). Assemble upright by sliding crimped (2) and uncrimped (1) sections together and inserting lock screw (8). With the stand sitting upright on its casters, insert upright and secure with supplied 5/16" fasteners (7).

Install Elements: Lay heater housing face up on a stable work surface. Remove end reflectors. Remove grill guard by grasping center cross wire on guard, and with other hand, place thumb close to the grill's mounting hole. Gently press reflector away with your thumb while removing guard

center wire from hole. Remove center wire from bottom. Remove guard by sliding left then right. Carefully unpack element (note: it's made with quartz glass and can easily be broken). Place element in U-channel. Connect element lead wires with heater lead wires using supplied wire nuts. Reassemble heater.

Final Assembly: Attach cross arm to heater housing with supplied tab washer and knob. Install vertical sliding locking knob to cross arm and slide assembly onto upright post on stand; secure at desired position with locking knob. Wipe bulb clean with dry rag or rubbing alcohol.

First Use: Your Infratech curing system is ready for use. Only plug into a grounded power source. Position the system 18" or more away from the area to be cured. Normal operating distance is between 18" to 30".

WARNINGS:

NEVER block front of heater
DO NOT operate within 25' of flammable materials
DANGER: to reduce risk of explosion do not use within 10' of spraying operations while spraying

NEVER service heater without disconnecting from power
Source of possible shock
Use only with grounded power source
Use only grounded extension cords that are rated for the amp load of these units

OPERATING TIPS

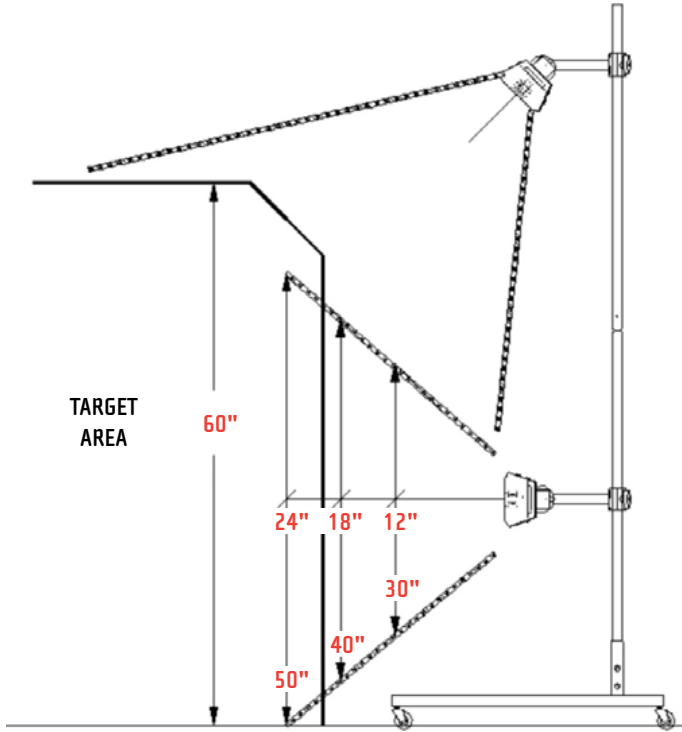

Your new Infratech infrared (IR) curing system provides fast, efficient curing for virtually every type of paint, primer, body filler, bonding adhesive and plastic repair product. Infratech infrared heats from the inside out, providing the best possible cure. It does not heat the air. IR cures fast by heating the coating and panel for the prescribed time to effect solvent evacuating and cross linking; the cure cycle is complete after the heated area cools back to room temperature. Once this full cycle is complete, the coating is fully cured and final assembly or cleanup for delivery can start. Care should be taken when using your new system. Operating the system too close to the part being cured can cause damage. When you first use your system, start at a distance of 24" to 30". As you gain experience using your system, you may be able to move the system closer (18" min. distance) to apply more heat and speed the curing cycle. Infratech heaters are powerful enough to blister paint and melt plastic. Additionally, it should be noted that different colors absorb IR at different rates.

CURING TIME

ITEM	DISTANCE FROM SURFACE	COVERAGE (H x W)	CURING TIME
2 K Primers	18-24"	3' x 4'	5-10 minutes
Waterborne Base Coat	18-24"	3' x 4'	3-6 minutes
Filler / Stoppers	18-24"	3' x 4'	7-10 minutes
Plastic Body Fillers	18-24"	3' x 4'	10-12 minutes
2K Plastic Repair	18-24"	3' x 4'	10-12 minutes
Acrylic Enamels	18-24"	3' x 4'	10-15 minutes
Polyurethane	18-24"	3' x 4'	15-20 minutes
Synthetic Enamels	18-24"	3' x 4'	15-20 minutes
High Solids Clear	18-24"	3' x 4'	10-15 minutes
2 K Top Coats	18-24"	3' x 4'	10-15 minutes
High Build Primers	18-24"	3' x 4'	15-18 minutes
Structural Adhesives	18-24"	3' x 4'	15-18 minutes

SPECIFICATIONS

PART NUMBER	MODEL	LENGTH	WATTS	VOLTS	AMPS	SHIPPING WEIGHT (LBS)
17-1015	SR-2	34"	1,650	120	13.8	24
17-1017	SR-2	34"	1,650	240	6.9	24

Need help? To order replacement elements for your Infratech heating system, please contact us via phone or visit the automotive section of our website.